

# Offer Form - AG

Please, fill and send us by FAX or by E-MAIL the following technical form

## SUBJECT:

OFFER REQUEST   
 ORDER ENCLOSURE   
 DATE \_\_\_\_\_

A (For flange fixing)

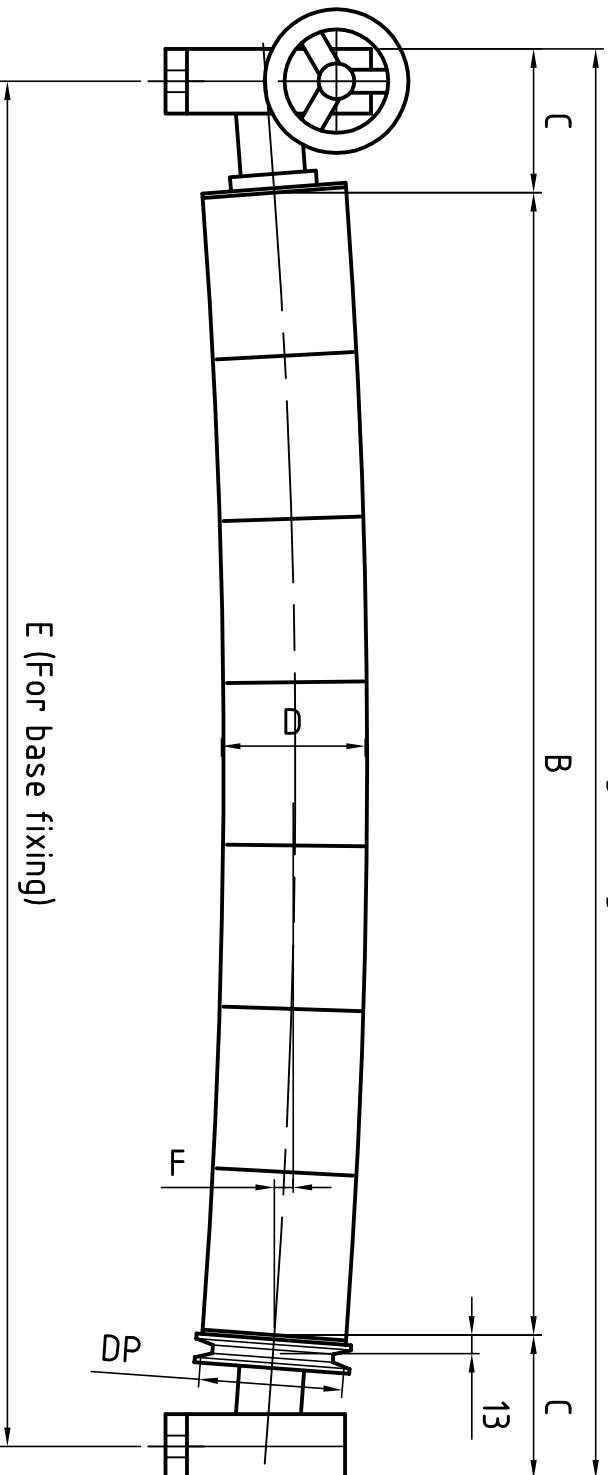

E (For base fixing)

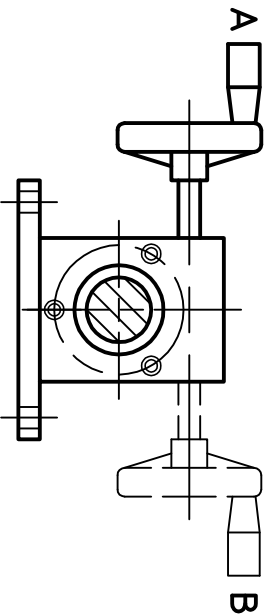

Note: If we don't receive different directions, the roller width will be centered with reference to the measures A and E.

Company \_\_\_\_\_

Road \_\_\_\_\_

Town \_\_\_\_\_

Ref. Mr. \_\_\_\_\_

Tel. n. \_\_\_\_\_ Fax. n. \_\_\_\_\_

E-mail \_\_\_\_\_

### WORKING DATA

Type of material \_\_\_\_\_  
 Maximum web tension kg. \_\_\_\_\_  
 Winding angle \_\_\_\_\_  
 Maximum operating speed \_\_\_\_\_  
 Material temperature \_\_\_\_\_  
 Environment temperature \_\_\_\_\_

### CONSTRUCTION DATA

Supports YES  NO   
 Supports type \_\_\_\_\_  
 Handwheel position A  B   
 Pulley YES  NO   
 Trapezoidal type  
 DP. mm. \_\_\_\_\_  
 Sec. type \_\_\_\_\_  
 Round type  
 DP. mm. \_\_\_\_\_  
 Cord  $\phi$  mm. \_\_\_\_\_  
 Flat type  
 DP. mm. \_\_\_\_\_  
 Width 23 mm.  
 Chromium Plating YES  NO   
 No of pieces \_\_\_\_\_

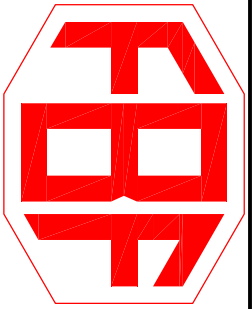

## Offer Form - AGV

Please, fill and send us by FAX or by E-MAIL the following technical form

### SUBJECT:

OFFER REQUEST   
 ORDER ENCLOSURE   
 DATE \_\_\_\_\_

Company \_\_\_\_\_  
 Road \_\_\_\_\_  
 Town \_\_\_\_\_  
 Ref. Mr. \_\_\_\_\_  
 Tel. n. \_\_\_\_\_ Fax. n. \_\_\_\_\_  
 E-mail \_\_\_\_\_

### WORKING DATA

Type of material \_\_\_\_\_  
 Maximum web tension kg. \_\_\_\_\_  
 Winding angle \_\_\_\_\_  
 Maximum operating speed \_\_\_\_\_  
 Material temperature \_\_\_\_\_  
 Environment temperature \_\_\_\_\_

### CONSTRUCTION DATA

Supports YES  NO   
 Supports type \_\_\_\_\_  
 Handwheel position A  B   
 Pulley YES  NO   
 Trapezoidal type  
 DP. mm. \_\_\_\_\_  
 Sec. type \_\_\_\_\_  
 Round type  
 DP. mm. \_\_\_\_\_  
 Cord  $\phi$  mm. \_\_\_\_\_  
 Flat type  
 DP. mm. \_\_\_\_\_  
 Width 23 mm.  
 Chromium Plating SI  NO   
 Deflection regulation Manual  Hydraulic   
 N° of pieces \_\_\_\_\_

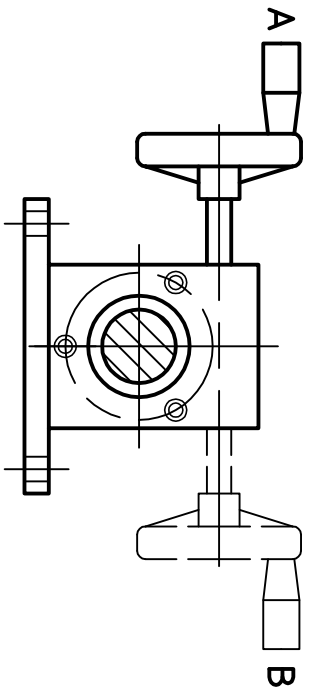
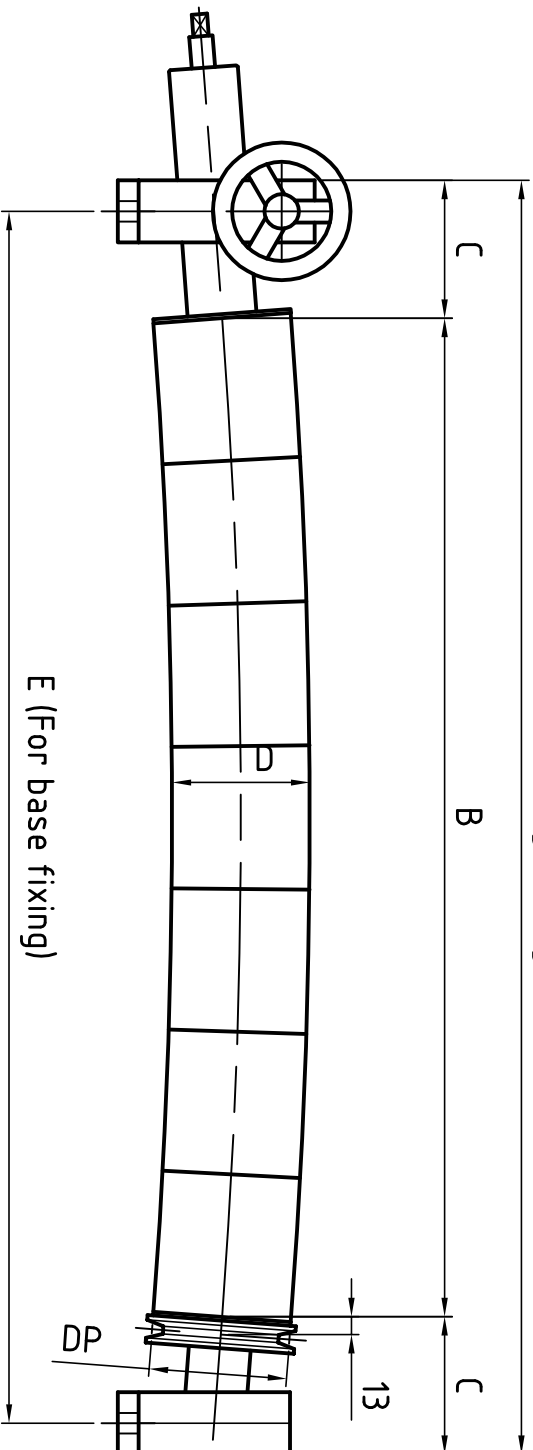

Note: If we don't receive different directions, the roller width will be centered with reference to the measures A and E.