

MADE IN ITALY

L'ESPANSIBILE THE EXPANDING SHAFT

Dispositivi ad espansione meccanica e pneumatica
Air expanding and mechanical shaft

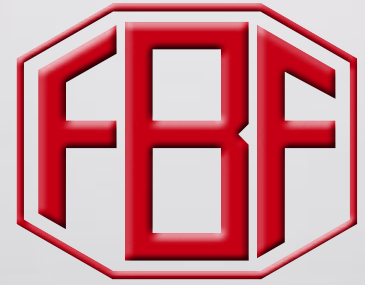

OFFICINA MECCANICA



ALTA
PRECISIONE
*HIGH
PRECISION*



ELEVATA
DURATA
LONG LIFE



PROGETTAZIONE
SU MISURA
*CUSTOM
DESIGN*



MADE
IN ITALY

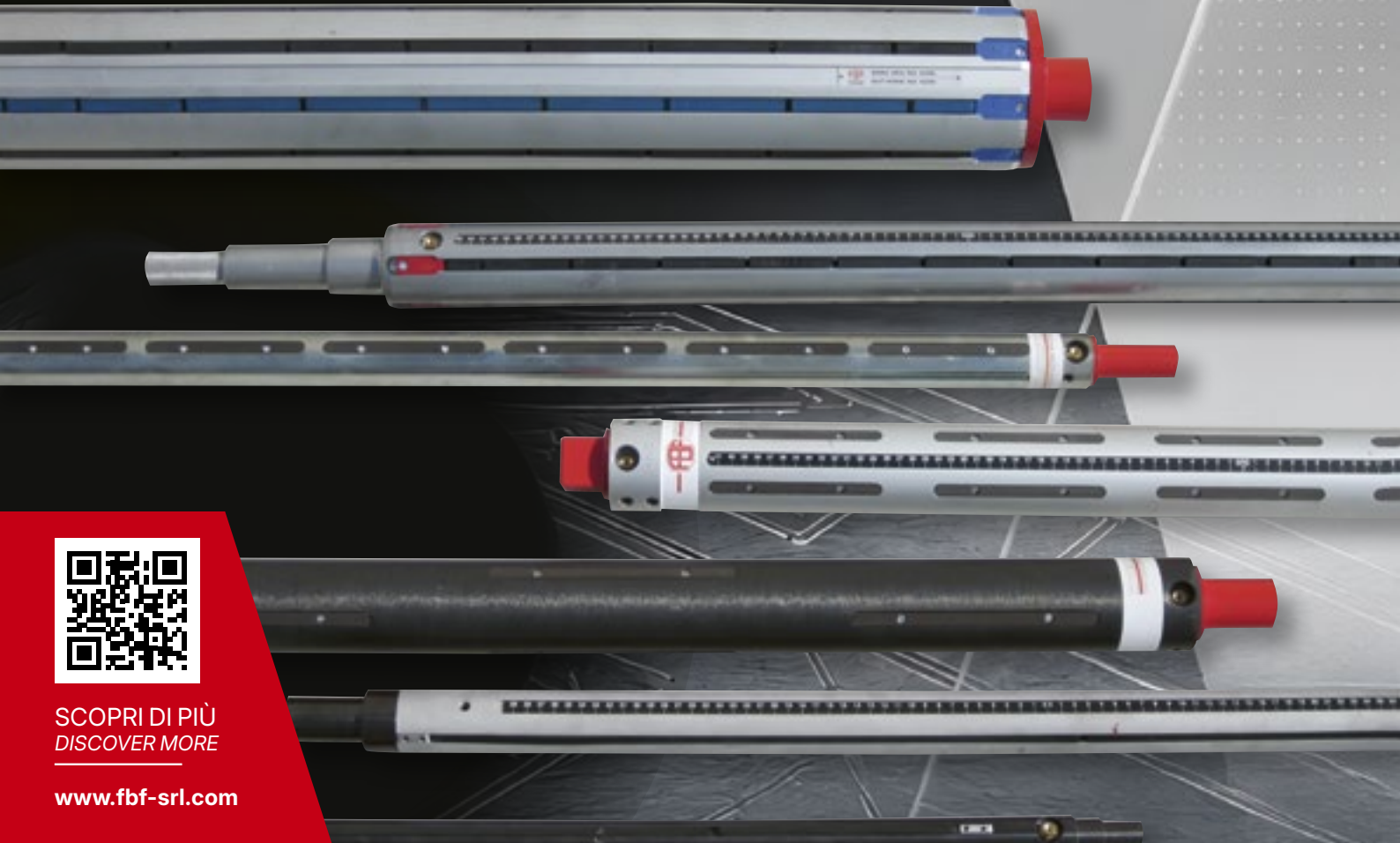

SCOPRI DI PIÙ
DISCOVER MORE

www.fbf-srl.com

APPLICAZIONI | *APPLICATIONS*



PACKAGING



FOOD



MEDICALE
MEDICAL



TESSILE
TEXTILE



AUTOMOTIVE

TECNOLOGIA E PRECISIONE AL SERVIZIO
DELLA TUA PRODUZIONE

*TECHNOLOGY AND PRECISION
FOR YOUR PRODUCTION*

LA NOSTRA AZIENDA

La ditta **FBF**, fondata nel 1977, è specializzata nella progettazione e nella costruzione di accessori e prodotti complementari alle macchine impiegate per la produzione delle materie plastiche, carta e tessuti.

Una costante della nostra produzione è la continua ricerca per il miglioramento dei nostri sistemi di lavoro che ci consentono una buona competitività di mercato e un continuo aggiornamento nell'organizzazione del lavoro.

Il sistema organizzativo aziendale opera in conformità alle prescrizioni della normativa ISO 9001, rispetto alla quale ha ottenuto la certificazione nel 1996. Il nostro ufficio tecnico è a disposizione per l'esecuzione di progetti che possano soddisfare le esigenze particolari di ogni cliente.

ABOUT US

*The company **FBF**, established in 1977, is specialized in the engineering and manufacturing of complementary products and accessories for plastic, paper and textile machines.*

We always improve our production systems and our internal organisation in order to be more and more competitive on the market and to reach the best reliability.

FBF works in conformity with the ISO 9001 quality system. It has been certified since 1996.

Our technical and commercial departments are always at your disposal for any special request.



ALTA
PRECISIONE
HIGH
PRECISION



ELEVATA
DURATA
LONG LIFE



PROGETTAZIONE
SU MISURA
CUSTOM
DESIGN



MADE
IN ITALY



GAMMA DI PRODUZIONE | PRODUCTION RANGE

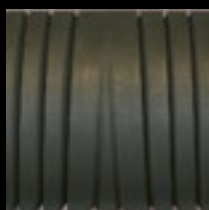
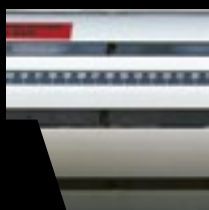



OFFICINA MECCANICA



CERTIFIED
ISO 9001

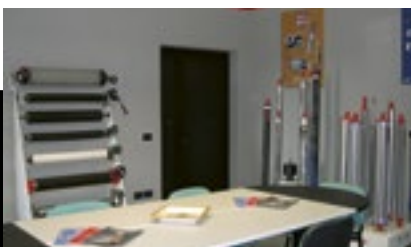

PACKAGING

FOOD

MEDICALE
MEDICAL

TESSILE
TEXTILE

AUTOMOTIVE



OFFICINA MECCANICA



OFFICINA MECCANICA

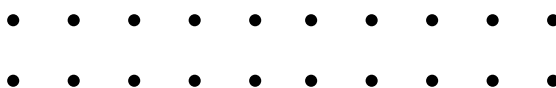

ALTA
PRECISIONE
HIGH
PRECISION



ELEVATA
DURATA
LONG LIFE



OFFICINA MECCANICA

LA NOSTRA GAMMA COMPRENDE:

OUR PRODUCTION CONSISTS OF:

PAGINA PAGE	TIPO DI ALBERO O DI TESTATA SHAFT OR HEADER MODEL	SERIE SERIES
4	Alberi pneumatici a chiavette in acciaio <i>Air expanding shafts with steel splines</i>	APC
5	Alberi pneumatici a listelli in gomma <i>Air expanding shafts with rubber splines</i>	APL
6	Alberi a sbalzo - <i>Embossed shafts</i>	AS
7	Alberi pneumo-meccanici <i>Air expanding mechanical shafts</i>	APM-APMSE
8	Alberi meccanici - <i>Mechanical shafts</i>	AM
9	Testate pneumo-meccaniche <i>Air expanding mechanical headers</i>	TPM-TPMSE
10	Testate meccaniche a spinta assiale <i>Axial thrust mechanical headers</i>	TMS
11	Testate pneumatiche a chiavette <i>Air expanding steel headers</i>	TC/TCB
12	Testate pneumatiche in gomma <i>Air expanding rubber headers</i>	TG/TGB
13	Alberi porta controcoltelli - <i>Counterknife holder shafts</i>	
13	Supporti rotanti per alberi - <i>Shaft rotary supports</i>	
13	Testata solleva-bobine - <i>Bobbin lifting header</i>	
14	Formulario per offerte	
15	Offer form	

ACCESSORIES, SPARE PARTS AND SERVICE



PROGETTAZIONE
SU MISURA
CUSTOM
DESIGN

- The supply of air expanding shafts and headers includes:
- An inflating device.
- Instructions for the inner tube replacement.
- Drawings of the shaft details and respective codes.
- The supply of mechanical shafts includes the control key.
- Our after-sales service assures the repairing of our shafts in a very short time.

ACCESSORI, RICAMBI E RIPARAZIONI

- Nella fornitura di alberi pneumatici e testate pneumatiche si includono pistola di gonfiaggio e istruzioni per il ricambio della camera d'aria.
- L'allegato per la sostituzione della camera d'aria include anche i disegni dei particolari che compongono l'albero con i relativi codici di individuazione.
- Nella fornitura degli alberi meccanici si include la chiave di manovra.
- Il nostro reparto assistenza è strutturato per eseguire in tempi brevi la riparazione dei nostri alberi e testate.

ALBERI PNEUMATICI A CHIAVETTE IN ACCIAIO serie APC

Caratteristiche tecniche

- Camera d'aria unica.
- Valvolina di gonfiaggio incassata sul fusto o su uno dei terminali.
- Fusto in alluminio o in acciaio.
- Per applicazioni particolari è prevista l'esecuzione con fusto in fibra di carbonio o in carbonio + acciaio.
- Morsetti in acciaio.
- Per anime \varnothing 50, 70, 76, (3"), ed altri diametri a richiesta.
- La distanza tra i morsetti viene stabilita in base alla lunghezza delle anime.
- La tavola può essere fissa (perni solidali al fusto) o rotante (perni rotanti rispetto al fusto).
- Possibilità di avere 5 morsetti oppure 3 morsetti sfalsati sulla circonferenza (serie 70-76).
- Per altri diametri il numero dei morsetti è stabilito in funzione del diametro stesso.
- Versione \varnothing 70 e \varnothing 76 in acciaio speciale per alte portate di carico di bobina.

APC AIR EXPANDING SHAFTS WITH STEEL SPLINES

Main features:

- One inner tube.
- An air inflating valve, placed on the shaft or on one of the two terminals.
- Aluminium or steel shaft.
- Carbon shafts or carbon + steel shafts can also be manufactured for special needs.
- Steel splines.
- Core standard diameter: \varnothing 50, 70, 76, (3"). Other diameter dimensions are also available.
- The distance between the splines is calculated according to the core length.
- Rotary or integral shaft.
- 3 or 5 splines, staggered along the circumference (70 or 76 series).
- The number of splines depends on the diameter.
- Special steel version \varnothing 70 and \varnothing 76 to use with high weight of bobbin.

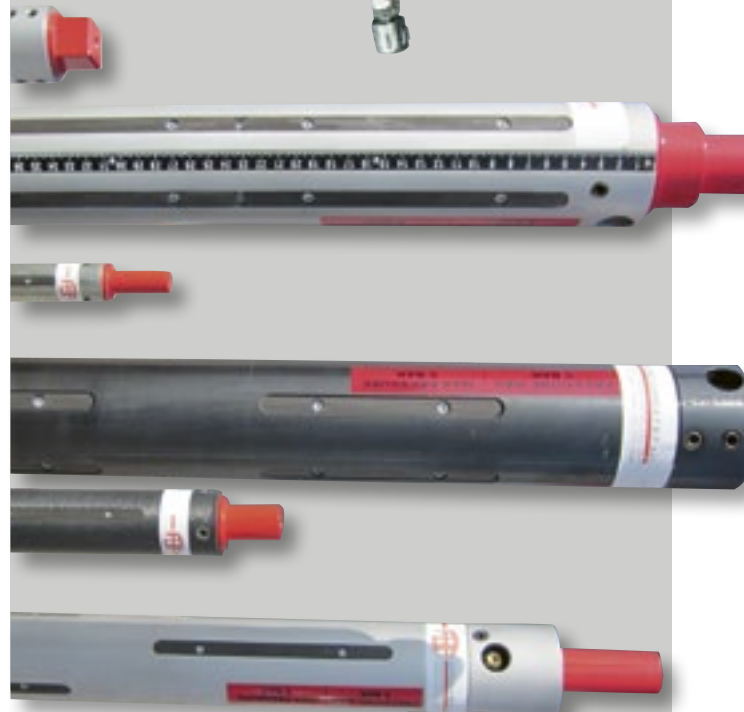

A 5 file di morsetti allineati

5 rows lined-up splines

FUSTO IN ACCIAIO O IN ALLUMINIO
STEEL OR ALUMINIUM SHAFT



A 3 file di morsetti sfalsati

3 rows staggered splines

MORSETTO
SPLINE

SETTORE
SECTOR

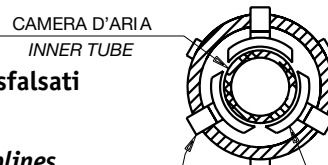

ESECUZIONE IN TAVOLA FISSA
INTEGRAL SHAFT



ESECUZIONE IN TAVOLA ROTANTE
ROTARY SHAFT

ALBERI PNEUMATICI A LISTELLI IN GOMMA serie APL

Caratteristiche tecniche

- Camerine di gonfiaggio multiple (il loro numero dipende dal diametro).
- Valvolina di gonfiaggio incassata sul fusto o su uno dei terminali.
- Fusto in alluminio o in acciaio.
- Listelli in gomma shore 70 o in poliuretano.
- Per anime Ø 48 (2"), 70, 76 (3"), 152 (6"), ed altri diametri a richiesta.
- I listelli sono in continuo su tutta la tavola.
- La tavola può essere fissa (perni solidali al fusto) o rotante (perni rotanti rispetto al fusto).
- Alberi particolarmente indicati per avvolgimento di bobine multiple.
- Versione autocentrante a richiesta.

APL AIR EXPANDING SHAFTS WITH RUBBER SPLINES

Main features:

- Multiple air inflating tubes (the number depends on the diameter).
- An air inflating valve placed on the shaft or on one of the terminals.
- Aluminium or steel shaft.
- "Shore 70" rubber or polyurethane splines.
- Core standard diameter: Ø 48 (2"), 70, 76 (3"), 152 (6"). Other diameter dimensions are also available.
- Rubber splines placed along all the shaft.
- Rotary or integral shaft.
- This model is particularly suitable for winding multiple bobbins.
- Upon request, we can supply a self-centring model.



ALTA
PRECISIONE
HIGH
PRECISION



PROGETTAZIONE
SU MISURA
CUSTOM
DESIGN



ELEVATA
DURATA
LONG LIFE

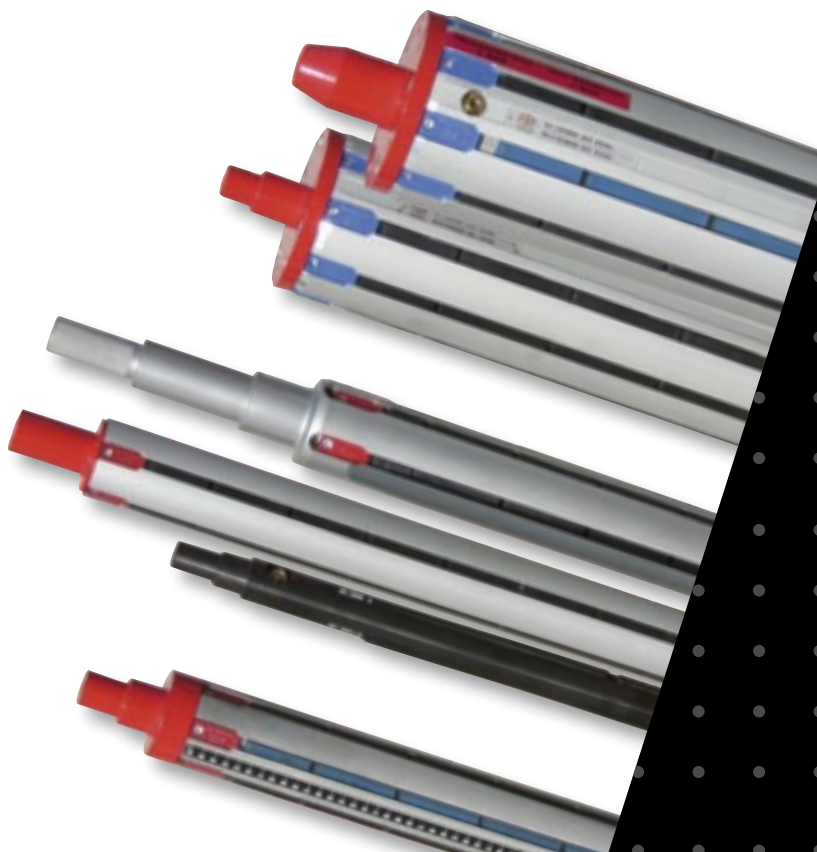
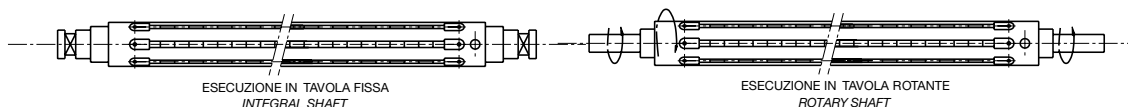

PACKAGING



FOOD



MEDICALE
MEDICAL



TESSILE
TEXTILE

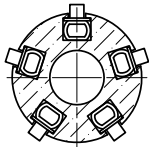
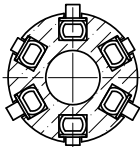
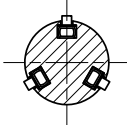
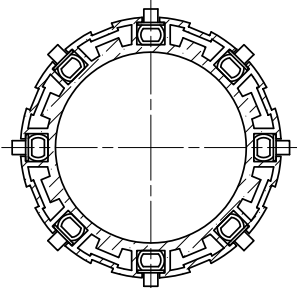
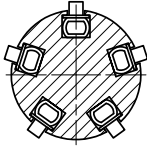
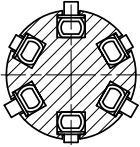
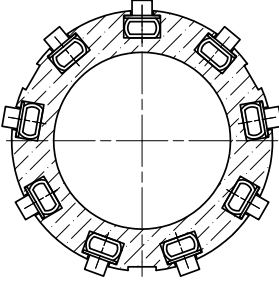
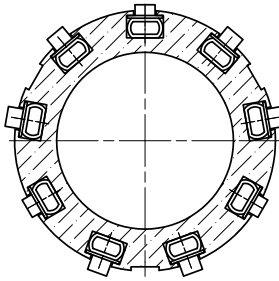

AUTOMOTIVE

<p>APL ALLUMINIO 3" APL ALUMINIUM 3"</p>  <p>5 MORSETTI DI BLOCCAGGIO 5 BLOCKING RUBBER SPLINES</p>	<p>APL ALLUMINIO AUTOCENTRANTE 3" SELF-CENTRING APL IIN ALUMINIUM 3"</p>  <p>3 MORSETTI DI BLOCCAGGIO + 3 MORSETTI DI CENTRAGGIO 3 BLOCKING RUBBER SPLINES + 3 CENTRING RUBBER SPLINES</p>	<p>APL ALLUMINIO O ACCIAIO 2" APL ALUMINIUM OR STEEL 2"</p>  <p>3 MORSETTI DI BLOCCAGGIO 3 BLOCKING RUBBER SPLINES</p>	<p>APL ALLUMINIO 6" APL IN ALUMINIUM 6"</p>  <p>8 MORSETTI DI BLOCCAGGIO 8 BLOCKING RUBBER SPLINES</p>
<p>APL R51 ACCIAIO 3" APL IN R51 STEEL 3"</p>  <p>5 MORSETTI DI BLOCCAGGIO 5 BLOCKING RUBBER SPLINES</p>	<p>APL R51 ACCIAIO AUTOCENTRANTE 3" SELF-CENTRING APL IN R51 STEEL 3"</p>  <p>3 MORSETTI DI BLOCCAGGIO + 3 MORSETTI DI CENTRAGGIO 3 BLOCKING RUBBER SPLINES + 3 CENTRING RUBBER SPLINES</p>	<p>APL HL IN ALLUMINIO 6" (ALTA PORTATA) APL HL IN ALUMINIUM 6" (HIGH LOADING)</p>  <p>9 MORSETTI IN GOMMA 9 BLOCKING RUBBER SPLINES</p>  <p>6 MORSETTI DI BLOCCAGGIO + 3 MORSETTI DI CENTRAGGIO 6 BLOCKING RUBBER SPLINES + 3 CENTRING RUBBER SPLINES</p>	

ALBERI A SBALZO serie AS

Caratteristiche tecniche:

- Sono esecuzioni particolari delle serie viste in precedenza (APC / APL / AM / APM) in quanto una delle due estremità viene inserita nell'appoggio della macchina mentre l'altra rimane senza sostegno.
- Normalmente vengono eseguiti in acciaio, ma per portate particolarmente limitate possono essere costruiti con fusto in alluminio.
- Per il comando di espansione degli alberi pneumatici esistono due possibilità:
 - 1) valvola in testa sull'estremità che rimane a sbalzo.
 - 2) foro filettato di dimensioni a richiesta sull'estremità che viene inserita nella macchina.

AS EMBOSSED SHAFTS

Main features:

- *Special model of shaft: one the two ends is set in the machine support; the other end is without any support.*
- *Made of steel for ordinary operations and of aluminium for limited load.*
- *Two models of expansion control are available:*
 - 1) *a valve placed on the head of the embossed end.*
 - 2) *a threaded hole on the end set in the machine (custom made dimensions).*



ALBERI PNEUMO-MECCANICI serie APM e APMSE



OFFICINA MECCANICA

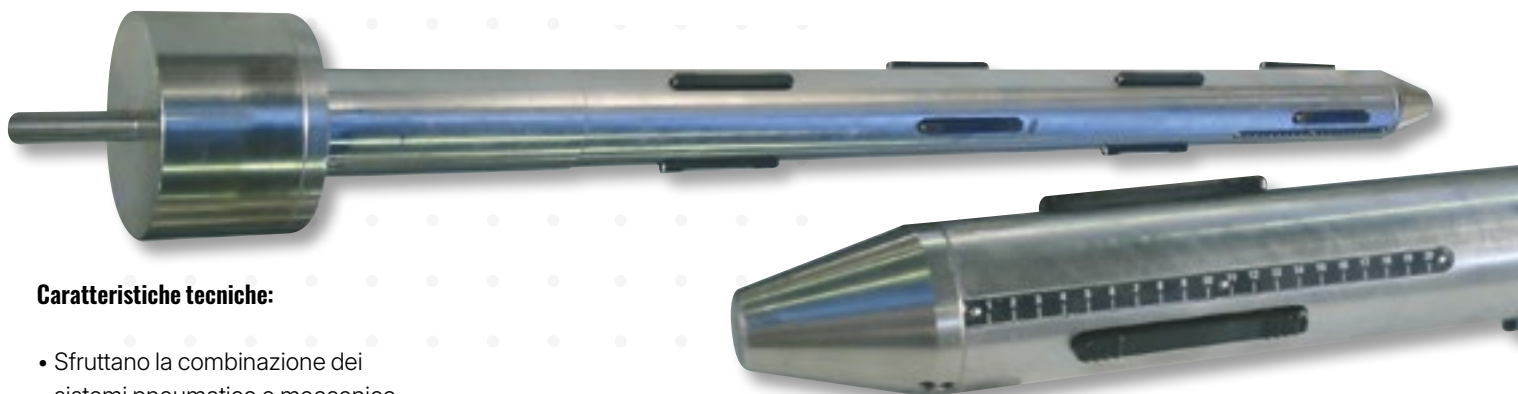

Caratteristiche tecniche:

- Sfruttano la combinazione dei sistemi pneumatico e meccanico.
- L'albero pneumo-meccanico monta i morsetti dell'albero meccanico tradizionale.
- I diametri standard sono: 70-76-152
- È garantito lo stesso grado di centratura dell'albero meccanico con i vantaggi del comando pneumatico, cioè un più rapido comando di espansione.
- **Serie APM:** la forza che determina l'espansione dei morsetti è data dall'ingresso dell'aria che spinge un pistone. Togliendo la pressione dell'aria le molle permettono il ritorno del pistone e il conseguente ritiro dei morsetti. Nel cilindro è ricavato un foro di sfiato che serve per un eventuale aiuto al ritorno del pistone.
- **Serie APMSE:** immettendo la pressione dell'aria le molle vengono compresse e permettono il ritiro dei morsetti.

PNEUMO - MECCANICO 3" | PNEUMO - MECHANICAL SHAFT 3"

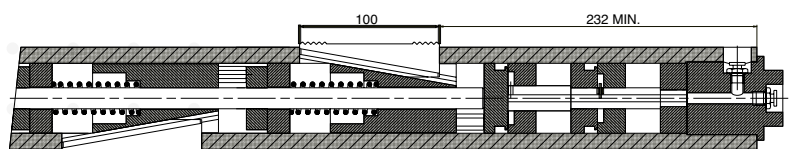

PNEUMO - MECCANICO 6" | PNEUMO - MECHANICAL SHAFT 6"

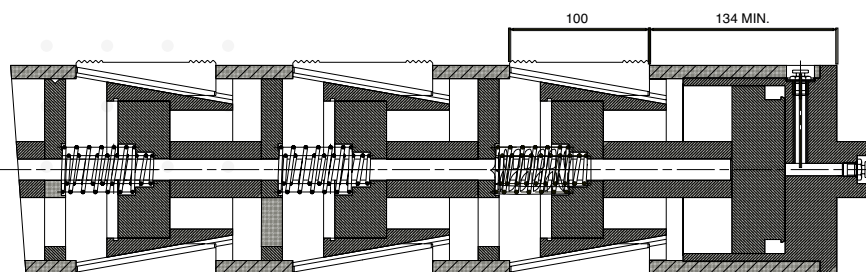

APM and APMSE AIR EXPANDING MECHANICAL SHAFTS

Main features:

- It combines the air expanding system with the mechanical one.
- Same model of splines used for the mechanical shaft.
- Standard core diameters: 70-76-152
- Same core centring of the mechanical shaft. The advantage is given by the

air expanding control, i.e. a quiker expansion control.

- **Model APM:** splines expansion caused by the entrance of air, which thrusts a piston. Relieving the air pressure the springs allow the piston reversal and the splines contraction.

A vent in the cylinder makes the piston reversal easy.

- **Model APMSE:** inflating the air pressure the springs are compressed to obtain the splines contraction.

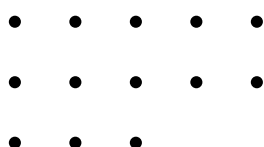

ALTA
PRECISIONE
HIGH
PRECISION



ELEVATA
DURATA
LONG LIFE



PROGETTAZIONE
SU MISURA
CUSTOM
DESIGN



ALBERI MECCANICI serie AM

Caratteristiche tecniche:

- Il loro funzionamento consiste nella fuoriuscita di morsetti in acciaio situati in una serie di coni. Tale fuoriuscita è causata dall'azionamento di una vite di manovra posta in testa ad uno dei terminali dell'albero.
- Normalmente eseguiti con il fusto in acciaio.
- Morsetti in acciaio con una serie di denti ricavata sull'esterno per favorire la presa della bobina.
- Per anime \varnothing 70-76 i morsetti sulla circonferenza sono 3.
- Esecuzione in sola tavola fissa.
- Buon grado di centratura sul mandrino.
- Lunga durata di funzionamento nel tempo dovuta all'alta resistenza dei componenti.
- Non è necessaria alcuna manutenzione.
- Oltre alle misure standard per anime \varnothing 70-76 a richiesta si eseguono altre dimensioni.
- Versione \varnothing 70 e \varnothing 76 in acciaio speciale per alte portate di carico di bobina.

AM MECHANICAL SHAFTS

Main features:

- Working: the steel splines placed on a series of cones are driven out by a driving gear, placed on the top of one of the two terminals.
- Steel shaft.
- Steel splines with teeth on the exterior part, to grip the bobbin better.
- 3 steel splines placed along the circumference for \varnothing 70/76 cores.
- Only integral shaft available.
- Excellent core centring.
- Long duration guaranteed by the high resistance of the components.
- No maintenance required.
- Standard core diameter: \varnothing 70-76.
- Other dimensions are also available.
- Special steel version \varnothing 70 and 76 to use with high weight of bobbin.

ALBERO A 3 MORSETTI MECCANICO | 3 SPLINES MECHANICAL SHAFT

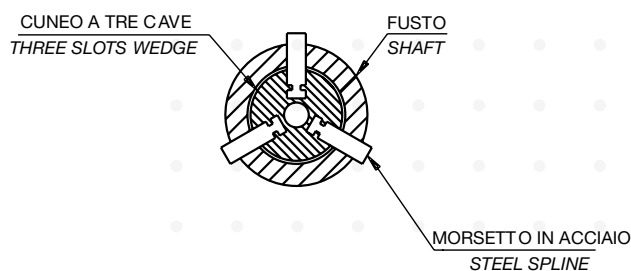

ALBERO MECCANICO | MECHANICAL SHAFT

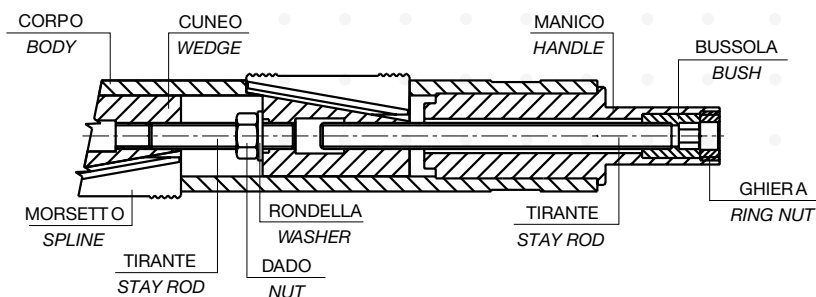

TESTATE PNEUMO- MECCANICHE serie TPM e TPMSE



Caratteristiche tecniche:

- Come per gli alberi pneumo-meccanici, questo tipo di testata sfrutta la combinazione dei sistemi meccanico e pneumatico.
- Morsetti in acciaio.
- I diametri standard sono: 70-76 (corsa 68-78) e 152 (corsa 148-158).
- Le dimensioni di alloggiamento devono essere adattate alla macchina del cliente, come per gli alberi espansibili.
- **Serie TPM:** l'espansione dei morsetti è data dalla spinta di un pistone azionato dall'ingresso dell'aria. Lo sblocco avviene con ritorno a molla. Sulla testata è ricavato un foro di sfiato che serve per un eventuale aiuto di ritorno del pistone.
- **Serie TPMSE:** immettendo la pressione dell'aria le molle vengono compresse e permettono il ritorno dei morsetti.



TESTATA PNEUMO - MECCANICA CON RITORNO A MOLLA ANIME Ø 70/76

AIR EXPANDING MECHANICAL SPRING RETURN HEADER CORE Ø 70/76

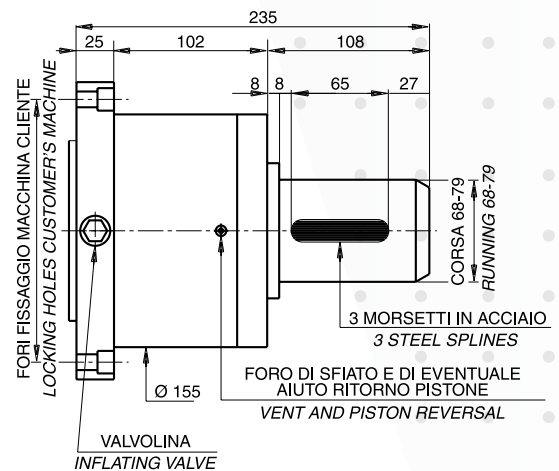

TESTATA PNEUMO - MECCANICA CON RITORNO A MOLLA ANIME Ø 152

AIR EXPANDING MECHANICAL SPRING RETURN HEADER CORE Ø 152

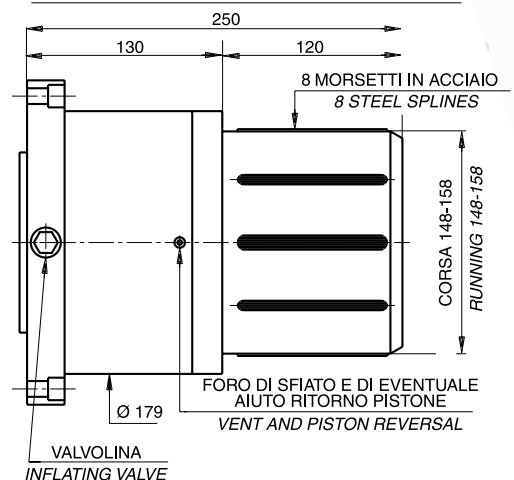

TPM and TPMSE AIR EXPANDING MECHANICAL HEADERS

Main features:

- It combines the mechanical system with the air expanding one.
- Steel splines.
- Standard core diameter: 70/76 (68/78), 152 (148-158).
- Slot dimensions in accordance with customer's machine.
- **TPM:** splines expansion caused by the entrance of air, which thrusts a piston. Spring back release. A vent makes the piston reversal easy.
- **TPMSE:** inflating the air pressure the springs are compressed to obtain the splines contraction.



TESTATE MECCANICHE A SPINTA ASSIALE serie TMS

Caratteristiche tecniche:

- L'espansione avviene per mezzo della spinta meccanica dell'anima porta bobine contro il disco di spinta della testata.
- Lo sblocco avviene attraverso l'allontanamento della bobina, che permette alle molle all'interno della testata di esercitare una spinta che fa arretrare i morsetti.
- Morsetti in acciaio.
- Le dimensioni di alloggiamento devono essere adattate alla macchina del cliente.
- I diametri sono il 70-76 (corsa 68-78) e il 152 (corsa 148-158).



TMS axial thrust MECHANICAL HEADERS

Main features:

- Expansion caused by the mechanical thrust against the header thrust disk.
- Release caused by the roll removal, which allows the springs inside the header to practice a thrust for the release of the splines.
- Same model of splines used for the mechanical shaft.
- Steel splines.
- Standard core diameters: 70/76 (68/78), 152 (148/158).

per anime Ø 152 | Ø 152 cores

PER ANIME Ø 70-76 | Ø 70-76 CORES

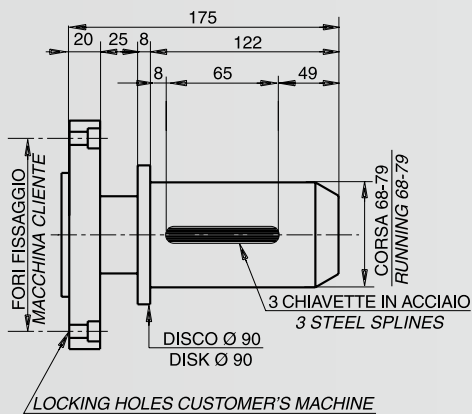
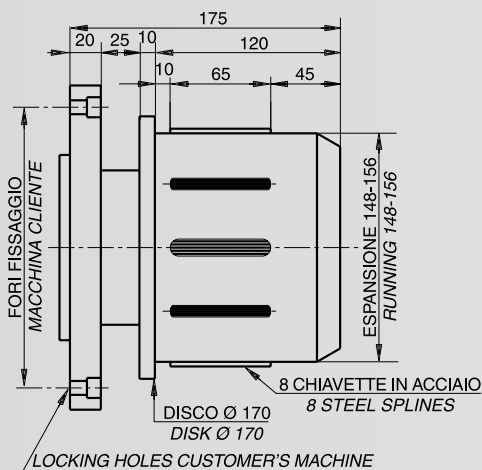

TESTATE PNEUMATICHE A CHIAVETTE serie TC/TCB



OFFICINA MECCANICA

Caratteristiche tecniche:

- Espansione pneumatica tramite camera d'aria unica e ritorno con scarico aria.
- Bloccaggio con chiavette in acciaio.
- Solitamente il fissaggio all'albero sottostante avviene tramite le 2 viti di bloccaggio poste sulle flange.
- Le testate pneumatiche a chiavette possono essere collegate tra loro per mezzo di raccordi di collegamento per facilitare l'operazione di gonfiaggio mediante valvola unica.
- Normalmente le testate vengono fornite in coppia, e una delle due ha un bordino di battuta per le bobine (TCB), mentre l'altra è normale (TC).
- La gamma delle dimensioni è raccolta nella tabella sottostante.

TESTATE PNEUMATICHE A CHIAVETTE
CON RACCORDI DI COLLEGAMENTO
AIR EXPANDING SPLINES HEADER WITH
CONNECTORS

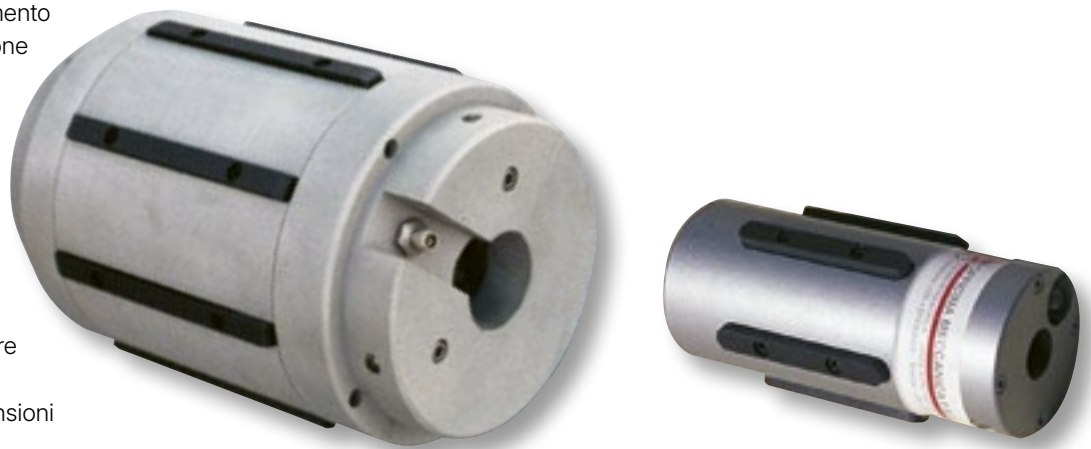
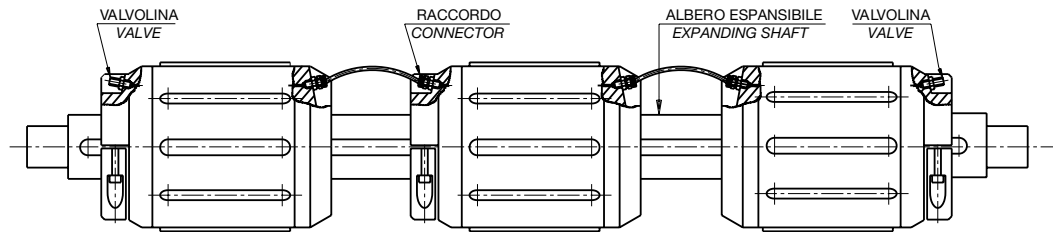

TC/TCB AIR EXPANDING HEADERS

Main features:

- One air tube air expansion and air blowdown reversal.
- Steel splines blocking.
- Two blockings crews placed on the flanges secure the header to the shaft.
- The splines air expanding headers can be joined to each other by connectors, to make the one valve inflation easy.
- The headers are usually supplied two by two: one has a thrust collar for bobbins (TCB); the other one is ordinary (TC).
- See below the available dimensions.

DIMENSIONI DI INGOMBRO OVERALL DIMENSIONS

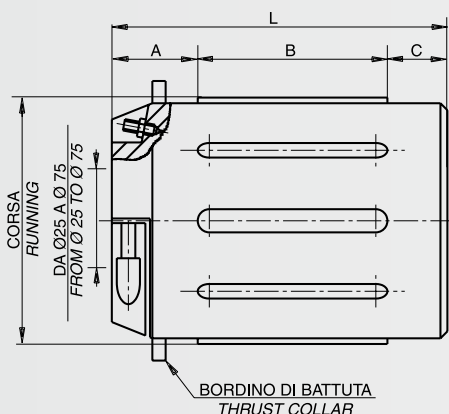

TIPI E DIMENSIONI MODELS AND DIMENSIONS

tipo type	anima Ø cores Ø	corsa running	L	A	B	C
1	70-76	68-78	160	48	79	33
2	152	149-155	224	54	124	46
3	200	197-203,5	274	54	174	46
4	203	199-205,5	274	54	174	46
5	217	214-220	274	54	174	46
6	254	250-257	274	54	174	46
7	300	296-304	274	54	174	46
8	320	316-324	274	54	174	46

NOTA: per la testata anime 70-76 il foro centrale è di 20 mm
NOTE: for the 70-76 cores header, the central hole is 20 mm



ELEVATA
DURATA
LONG LIFE



TESSILE
TEXTILE



AUTOMOTIVE

TESTATE PNEUMATICHE IN GOMMA serie TG/TGB

Caratteristiche tecniche:

- Sono costituite da un corpo centrale in gomma e da due flange in alluminio.
- Il bloccaggio dell'anima è data dall'espansione del corpo in gomma.
- Lo sgonfiaggio avviene come per gli alberi pneumatici normali, cioè per scarico aria.
- Questa gamma comprende le anime da $\varnothing 76$ e 152 mm.
- Normalmente le testate vengono fornite in coppia, e una delle due ha un bordino di battuta per le bobine (TGB), mentre l'altra è normale (TG).
- Il fissaggio dell'albero avviene tramite due viti di bloccaggio poste su una delle due flange.
- Anche le testate in gomma possono essere collegate fra loro per mezzo di raccordi di collegamento.



PROGETTAZIONE
SU MISURA
CUSTOM
DESIGN

TG/TGB AIR EXPANDING RUBBER HEADERS

Main features:

- This model consists of a central rubber body and 2 aluminium flanges.
- Core blocking caused by the rubber body expansion.
- Same deflation system of the ordinary air expansion shaft; i.e. air blowdown.
- Core standard diameter: 76/152 mm and other diameters.
- The headers are usually supplied two by two; one has a thrust collar for bobbins (TGB); the other one is ordinary (TG);
- Two blocking screw placed on one of the two flanges secure the header to the shaft.
- The rubber headers can be joined to each other by connectors.

TESTATE PNEUMATICHE IN GOMMA CON RACCORDI DI COLLEGAMENTO
AIR EXPANDING RUBBER HEADERS WITH CONNECTORS

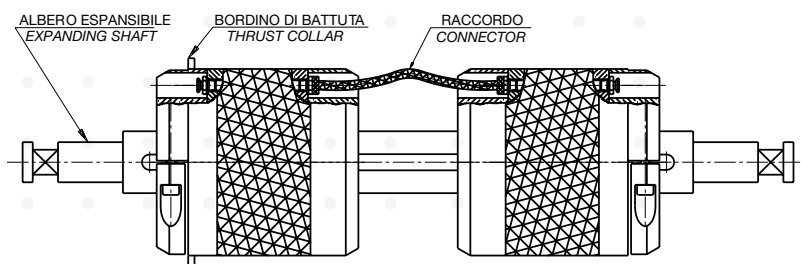

TESTATE PER ANIME $\varnothing 74$
 $\varnothing 74$ HEADER CORE

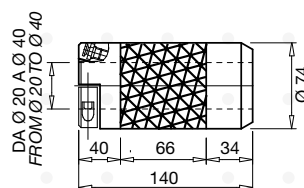

TESTATE PER ANIME $\varnothing 152$
 $\varnothing 152$ HEADER CORE

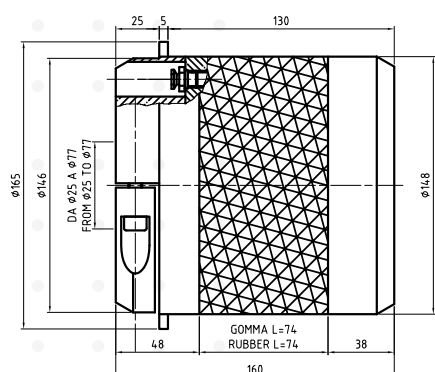

ALBERI PORTA CONTROCOLTELLI

Caratteristiche tecniche:

- Il corpo e i manici sono costituiti da un pezzo unico, e grazie a ciò questo tipo di albero presenta un ottimo grado di concentricità e tolleranze dimensionali, che rendono l'operazione di taglio molto precisa.
- Nel corpo sono ricavate alcune scanalature (il numero dipende dal diametro dell'albero) contenenti ciascuna un morsetto in gomma dura ed acciaio lungo tutta la tavola.
- Il sistema di espansione permette di spostare i controcoltelli lungo la tavola dell'albero attraverso lo sgonfiaggio e il rigonfiaggio delle camere d'aria.

COUNTERKNIFE-HOLDERS SHAFTS

Main features:

- The body and the terminals are made in one piece, and for this reason the shaft has an optimum standard of concentricity and dimensional tolerance. These two make the cutting operation very accurate.
- Some grooves are drawn in the body (their number depends to the diameter of the shaft) and they contain each one a rubber and steel spline along the body.
- The expansion system allows to move the counterknives along the table of the shaft through the deflating and the inflating of the inner tubes.



MADE IN ITALY



OFFICINA MECCANICA

SUPPORTI ROTANTI PER ALBERI

Caratteristiche tecniche:

- Servono nel caso in cui la macchina sulla quale vanno montati gli alberi non abbiano una sede predisposta a sostenerli.
- Si dividono in diversi modelli a seconda del tipo di impiego e dimensioni.
- I vari modelli sono raffigurati in una raccolta di disegni che deve essere richiesta separatamente.



SHAFT ROTARY SUPPORTS

Main features:

- They are used when the machine has no shaft supports.
- Different models according to any applications and dimensions are available;
- A collection of the whole range drawings can be requested by the customer.

TESTATA SOLLEVA-BOBINE

Caratteristiche tecniche:

- Serve per il sollevamento di bobine con anime di cartone Ø 76 mm.
- Per una maggiore sicurezza i morsetti della testata sono sempre espansi meccanicamente. Il ritorno dei morsetti per lo sfilamento della testata dalla bobina avviene immettendo dell'aria.
- Morsetti zigrinati in acciaio cementato.
- Testata in versione unica con misure come da disegno.
- Peso bobina indicativo: 600 Kg.

BOBBIN LIFTING HEADER

Main features:

- It is used to lift up the bobbin with a 76 mm cartoon core diameter.
- For security reasons the steel splines are always mechanically expanded. The contraction of the splines is achieved by inflating the air.
- Cemented steel splines with grooves.
- One model available; see the drawing.
- Max loading suggested: 600 Kg.

SOLLEVATORE PNEUMO - MECCANICO 3"
BOBBIN LIFTING HEADER 3"

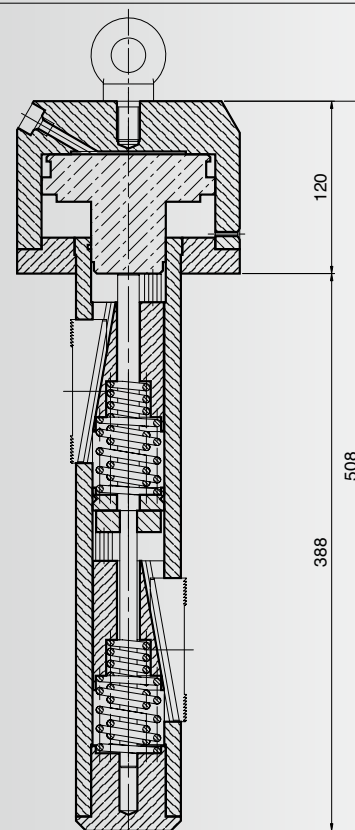

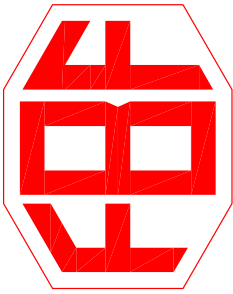

Offer Form

Please, fill and send us by FAX or by E-MAIL the following technical form

SUBJECT:

OFFER REQUEST
ORDER ENCLOSURE

DATE _____

Company _____
Road _____
Town _____
Ref. Mr. _____
Tel. n. _____ Fax. n. _____
E-mail _____

Please, draw the terminals of your shaft and specify the valve or the control key position

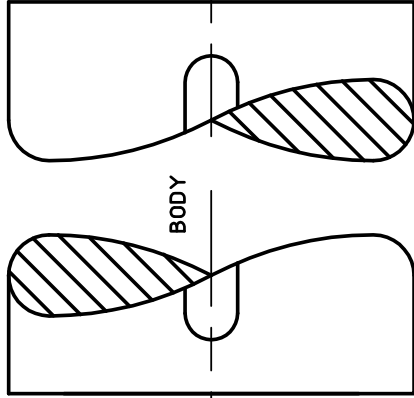

Winding
Unwinding
Core Int. ϕ _____
Core Ext. ϕ _____
Core Material _____
Board _____
Plastic _____
Steel _____

Bobbin max width _____ mm.
weight Kg. _____
 ϕ _____ mm.
Bobbin min width _____ mm.
weight Kg. _____
 ϕ _____ mm.
Max. Speed. _____ mt/min.
Bobbins n. per shaft _____
Wind/Unwind material _____
Paper
Film
Matched
Other
Kg. _____

Max tension _____ Kg.

BOBBINS SEQUENCE

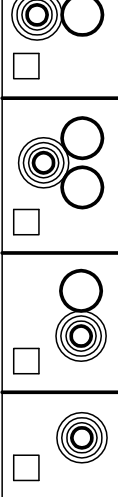

Shaft material: _____
Steel
Aluminium
Air Expanding _____
Mechanical _____
Integral Hub _____
Idle Hub _____
Pieces N. _____

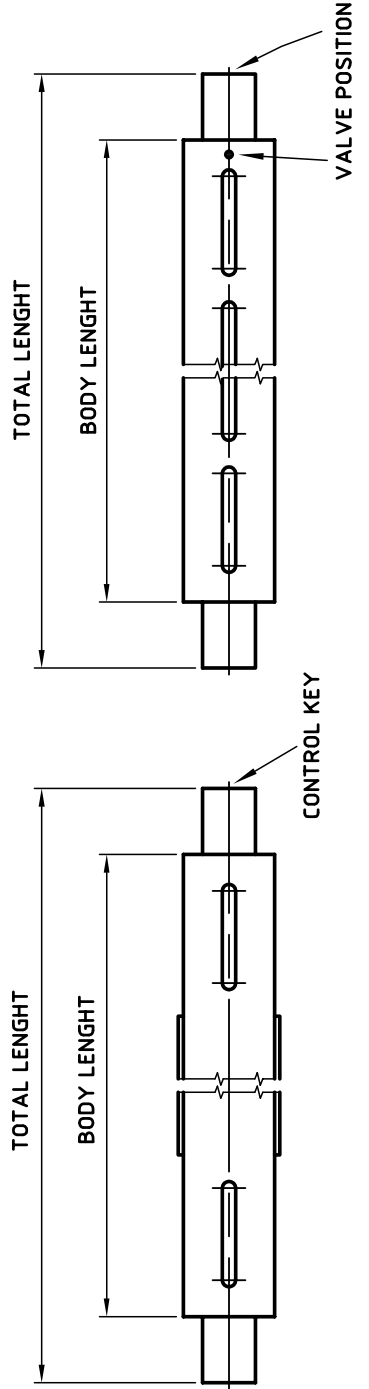

MADE IN ITALY



OFFICINA MECCANICA

FLESSIBILITÀ ed ELASTICITÀ... **in espansione**

Microforatori, Distensori ed Espansibili
*Microperforators, Spreader rollers and
Expanding shafts*

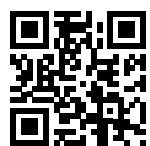
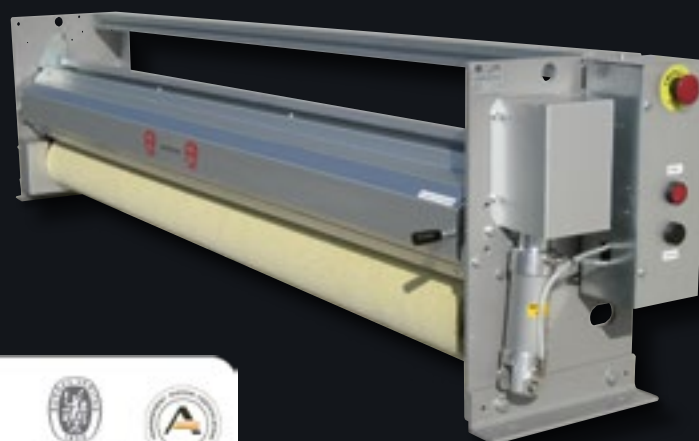

SCOPRI DI PIÙ
DISCOVER MORE

www.fbf-srl.com

CERTIFIED
ISO 9001





ALTA
PRECISIONE
*HIGH
PRECISION*



A FREDDO
E A CALDO
COLD & HOT



ELEVATA
DURATA
LONG LIFE



PROGETTAZIONE
SU MISURA
*CUSTOM
DESIGN*



OFFICINA MECCANICA

TECNOLOGIA E PRECISIONE AL SERVIZIO
DELLA TUA PRODUZIONE

*TECHNOLOGY AND PRECISION
FOR YOUR PRODUCTION*

APPLICAZIONI | APPLICATIONS



PACKAGING



FILTRAZIONE
FILTRATION



FOOD



MEDICALE
MEDICAL



TESSILE
TEXTILE



AUTOMOTIVE



MADE
IN ITALY

AGENTE DI ZONA / SALES AGENT:

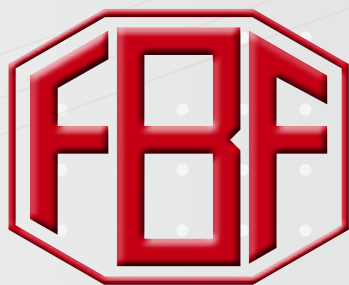

OFFICINA MECCANICA

MADE IN ITALY

SEDE E STABILIMENTO | SEAT AND FACTORY:

Via dell'Artigianato, 6

26029 SONCINO (CR) | ITALY

Tel. +39.0374.83063

info@fbf-srl.com



SCOPRI DI PIÙ
DISCOVER MORE

www.fbf-srl.com